

the  
**SUPER  
 SKYRIDER**  
 is  
**COMPLETE!**

**T**HE HAM that buys a Super Skyrider with Crystal Filter at \$89.50 is buying all that he needs for short wave reception. Here is a receiver that covers the radio spectrum with unsurpassed efficiency, including the standard broadcast band and the 10 meter band, so active of late. Recent Hallicrafters' laboratory developments have greatly increased the Super Skyrider efficiency on this particular band.

It's complete, without a single extra to buy, with a convenient band switch (no cumbersome plug-in coils), controlled Crystal Filter Circuit (an absolute necessity on any receiver because of amateur band congestion), 9 Metal Tubes with their superior performance characteristics, Iron Core I. F. System (first used on the Super Skyrider) and a dozen other exclusive Hallicrafter developments.

Think of these features when you're buying short wave reception, and see the Super Skyrider at your jobbers today. It's supreme for short wave reception and complete at a single moderate price.

- **9 Metal Tubes** — Dovetail perfectly with our efforts to improve signal to noise ratio — eliminate noisy tube shields — reduced inter-electrode capacities and shorter leads afford greater gain.
- **Iron Core I. F. System** — greatly increased sensitivity and a signal to noise ratio unattainable with an air core system.
- **Duo-Micro-Vernier Band Spread** — provide improved logging accuracy, — provides electrical band spreading and micro-vernier tuning in an exclusive and distinctive dial.

- More efficient **Crystal Filter Circuit**, controlled by variable knob on front of set gives one signal selectivity — without reducing sensitivity.
- **Beat Oscillator** with continuous range.
- **Modern Band Changing System** — any desired bands in the short wave spectrum with the turn of an exact positive switch — no cumbersome plug-in coils.
- **Compact** — all completely enclosed in one convenient and efficient cabinet 19¼" x 10" x 10".

**Hallicrafters  
 Mileage  
 Marathon**

The judges are swamped with reception reports from busy hams working the world to win the Mileage Marathon. It's the biggest event short wave radio has ever known. We tried, in vain, to check these reports as they came in but we're way behind. However, we are working night and day and hope to announce the winner in next month's QST.

SEE YOUR JOBBER TODAY OR WRITE FOR COMPLETE DETAILS



**the hallicrafters**

3001-Z Southport Avenue, Chicago, Illinois, U. S. A.

Cable Address: "LIKEX — New York"

# **SX-9 Super SKYRIDER by the hallicrafters**

## **OPERATING INSTRUCTIONS**

The band change switch should be tuned to the band desired. Then with the band spread condenser set to 200, move the main tuning control, which is the dial on the left, to any frequency desired within this band. The BFO switch can be either on or off. We recommend that it be on when attempting to locate weak phone stations, and it **MUST** be on when listening to CW.

On the main tuning dial there is a vernier scale under the dial light. This scale enables the operator to reset the main tuning dial accurately to within one-tenth of a division.

### **AVC SWITCH:**

For most efficient operation on code, keep AVC switch to “off” and audio gain set to 30% to 50%. Sensitivity and volume should be controlled by the R.F. Gain control. When AVC is set to “off”, the receiver may overload on a strong signal. Reduce R.F. gain to avoid overload.

When receiving controlled carrier modulation phone, the AVC should be switched off. It is advantageous to leave the AVC off when using the BFO.

The AVC should be on when receiving phone or short wave broadcasts, unless maximum sensitivity is needed. Whenever AVC is on, the R.F. Gain should be turned to full clockwise and volume of the radio should be controlled by audio gain. The R.F. Gain is used to control the sensitivity of the radio.

### **PITCH CONTROL:**

The BFO is very convenient in location distant or weak stations. Turn on your BFO and then turn your tuning dial to the approximate frequency of the station you are looking for. When the station is properly tuned in, the BFO will produce a whistling or rushing noise. You may now turn off the BFO to hear the station audio. For CW signals, leave the BFO on.

### **CRYSTAL PHASING CONTROL:**

Even without the crystal, the crystal phasing condenser will give some control over the selectivity of the radio. By setting this phasing control to the position of maximum background noise, this will give greater selectivity and sensitivity. This applies only when the crystal is not used. When the crystal is being used, the position of maximum noise becomes the position of minimum selectivity.

Contrary to usual belief, the crystal circuit in the 1936 Super SKYRIDER does not help materially in AM phone reception. Of course it is thoroughly known the crystal increases selectivity for CW reception. In receiving AM phone signals while using the crystal filter, it is recommended that the previously described position of maximum noise (minimum selectivity) be used first, then rotate the phasing knob toward minimum noise (maximum selectivity). Vary this adjustment until good quality voice is achieved.

For CW reception, it is recommended the crystal switch be “in” and the phasing knob set to minimum noise (maximum selectivity).

### **SEND RECEIVE SWITCH:**

This switch breaks the high voltage B supply, so the tube will not be paralyzed by a local transmitter.

# **SX-9 Super SKYRIDER by the hallicrafters**

## **CIRCUIT DESCRIPTION**

### **The Radio Uses Nine Tubes Of The Metal Type:**

6K7 - RF Amplifier - Preselector  
6L7 - 1<sup>st</sup> Detector - Mixer  
6C5 - Signal Frequency Local Oscillator  
6K7 - Intermediate Frequency Amplifier  
6H6 - 2<sup>nd</sup> Detector - AVC  
6F5 - 1<sup>st</sup> Audio Amplifier  
6F6 - 2<sup>nd</sup> Audio Power Amplifier (3.5 watts audio output)  
6K7 - Electron Coupled Beat Frequency Oscillator  
5Z4 - Rectifier

**The Antenna Circuit** is connected to the secondary of the R.F. coil by method of inductive and capacitive coupling. The inductive coupling acts at the high frequency ends of the bands for maximum transfer of the signal. The capacitive coupling (C8) does the major portion of the signal transfer at the low frequency ends of the bands. As seen in the circuit diagram, the unused coils on the secondary are shorted out.

**The 6K7** R.F. amplifier has a high inductance plate load which gives maximum transfer by use of capacity coupling at low frequency end of the bands. By use of coupling in C16 this is further increased. The normal characteristics of a coil and condenser are such that the gain varies about 3 to 1 from one end to the other, being maximum at high frequency end. The capacity coupling combines with this to level out the gain in this circuit to get uniformity throughout.

**The 6L7** used here as a detector-mixer has no parallel in glass tubes. The modulation from the oscillator circuit is supplied to this tube by use of an extra grid. Thanks to not having oscillator plate current flowing in the first detector, the ratio of translation to noise is considerably better than in composite tubes or in circuits where the cathodes of 2 tubes are connected together.

**The 6C5 OSCILLATOR** – covers only four bands. The harmonic of number 4 band is used to supply the oscillator voltage for conversion of signals to I.F. frequency, when using band 5. The oscillator circuit is a combination of the Hartley and the Colpitts, having the inherent features of both – the Hartley with the good oscillation at the high frequency ends of the bands and the Colpitts where oscillation is better at the low frequency ends of bands.

By this method, the oscillator generates a fairly constant voltage for impression on grid 3 of 6L7 over the full tuning range of the radio.

**The 1st I.F. TRANSFORMER** is made up of 3 coils phased in such a relation that maximum signal is impressed upon the low inductance primary of 2<sup>nd</sup> I.F. transformer. The crystal and crystal phasing circuit is inserted between these transformers in such a manner that when the crystal switch is at “in” position, the crystal and crystal phasing condenser cause single signal action to take place – this action varies by the setting of crystal condenser – when switch is at “out” position the signal is impressed directly on the second transformer.

**The 2<sup>nd</sup> I.F. TRANSFORMER** has a step up ratio so the the voltage impressed on grid of 6K7, I.F. amplifier is increased over the normal I.F. transformer connections. By the use of a transformer the grid circuit of this tube is tuned to the I.F. frequency, so that greater selectivity is achieved, than if a choke coil were used to supply this tube.

Transformers used at intermediate frequencies are of iron core construction – greater selectivity and gain, due to better Q of the coils is achievable than by the use of air core coils.

The signal to noise ratio if iron core coils, due to better Q, shows a marked improvement over other types of transformers.

**The 6K7 I.F. AMPLIFIER** is coupled through an iron core transformer to single diode plate of the 6F6. The single plate being used in order to lessen the load on the secondary of this transformer, making for greater selectivity in this circuit.

The ratios of AC & DC diode load are proportionate so that 100% modulation can be handled without distortion.

As will be noted from the circuit diagram (Fig. 2), the AVC voltage and the audio voltage are taken off slightly below the maximum point. This was done to reduce stray R.F. in the circuit and to give better AVC action on the R.F. 1<sup>st</sup> detector and I.F. stages.

**6K7 BEAT FREQUENCY OSCILLATOR** – this is an electron coupled oscillator – coupled to 6H6 diode plate by two turns of wire. Changes in line voltage and in tubes will not affect the frequency of beat oscillator. The frequency can be controlled by use of the pitch control in order that a receiving operator can beat on either side of signal getting further selectivity on code reception by choice of audio frequencies.

**AUDIO – FIRST STAGE AUDIO 6F5** - is a high MU triode. It is coupled to the diode circuit through its volume control (R20) and condenser (C25). As will be noted from the circuit no DC flows through this control, making for quiet operation.

**TONE CONTROL** – it will be noted that tone control (R22) is on plate of 6F5 and also on its grid circuit, when the control is full counter clockwise (treble position). The tone is normal. As the control is moved to the right up to one-half rotation the bass response is increased without cutting of high notes. Moved through the other half of the rotation the high notes are removed by use of condenser (C27) without further increasing the low note response.

In order to avoid frequency discrimination found in cathode – resistor – condenser bias circuits, the Mallory bias cell is used on the grid of 6F5. This proves a boon for phone operators in that it insures greater intelligibility in all voice, short wave broadcasts, etc.

**OUTPUT STAGE** – a 6F6 pentode, giving 3.5 watts output is connected to the speaker and headphone jack. This jack is arranged in circuit is such a way that when phones are inserted the voice coil of speaker is opened. A separate magnetic or permanent magnetic dynamic speaker can be plugged into the phone jack if external speaker is desired. Where an electrodynamic speaker has its own field supply, this too may be plugged in. Speaker impedance in these cases should be 7000 ohms, although other types can be used at a sacrifice in tone quality. No DC current flows though headphone circuit.

# **SX-9 Super SKYRIDER by the hallicrafters**

## **I.F. ALIGNMENT INSTRUCTIONS**

Correct alignment of any receiver is extremely important. The receiver when it leaves the factory is properly aligned with precision instruments and realignment should not be attempted until all other causes of faulty operation have been investigated and even then not unless the the service technician has the proper equipment. A signal generator that will provide an accurately calibrated signal at .465 m.c. - .8 m.c. - 1.4 m.c. - 1.8 m.c. - 3.6 m.c. - 4.2 m.c. - 9. m.c. - 20. m.c. & 30. m.c and an output indicating meter are required.

It is practically impossible to align the R.F. unless a satisfactory oscillator and output meter are used. Use a non-magnetic screw driver for adjustments. The complete procedure is as follows:

### **INTERMEDIATE FREQUENCY (“I.F.”) ADJUSTMENT:**

In a receiver which has a crystal filter, a crystal controlled signal generator must be used in which the crystal from the radio is borrowed and used in the frequency generator. Connect the output of this through a .1 mfd condenser to the grid cap of the 6L7. Connect the ground lead of the radio to the ground side of oscillator. (On a receiver without crystal filter, set the signal generator at 465 k.c.).

- Turn the band selector switch to band No. 1.
- Turn the AVC switch to the “off” position.
- Turn the audio gain and R.F. Gain controls to maximum position (full right).
- Turn the BFO switch to “off”.
- Set the crystal phasing condenser to one-half capacity (plates half inter-meshed).
- Attenuate the signal from the signal generator to prevent overloading the set.
- Use this procedure for all subsequent adjustments.

Now adjust the five trimmers on top of the I.F. cans until maximum output as indicated by the output meter. The adjustment screws are located in the top of the I.F. transformer cans, and may be reached from the top of the chassis.

### **BFO ADJUSTMENT:**

- Leave signal generator turned on from above.
- Set the pitch control condenser to one-half capacity (plates half inter-meshed).
- Turn the BFO switch to “on”.

Now adjust the trimmer on the top of BFO can for “zero-beat”.

# **SX-9 Super SKYRIDER by the hallicrafters**

## **R.F. ALIGNMENT INSTRUCTIONS**

**(Leave Band Spread at 200)**

### Alignment of band 5

- Connect antenna screw through a 400 ohm resistor to the signal generator.
- Set band switch to band 4.
- Leave both signal generator and radio dial at 20 m.c.
- Now adjust the underside trimmer screw OSC-4/5 to find the signal and maximize output.
- Set the signal generator to 30 m.c.
- Switch to band 5 and tune in the 30 m.c. signal.
- Now adjust the underside trimmer screws ANT-5 and DET-5 to maximize output.

### Alignment of band 4 (after completing band 5 above)

- Connect antenna screw through a 400 ohm resistor to the signal generator.
- Set signal generator to 18 m.c.
- Switch to band 4 and tune in the 18 m.c. signal.
- Adjust the underside trimmer screws ANT-4 and DET-4 to maximize output.
- Do not change OSC-4/5 screw already set for band 5 above.

### Alignment of band 3

- Connect antenna screw through a 400 ohm resistor to the signal generator.
- Leave both signal generator and radio dial at 9 m.c.
- Now adjust the underside trimmer screw OSC-3 to find the signal and maximize output.
- Next adjust the underside trimmer screws ANT-3 and DET-3 to maximize output.
- Change the signal generator to 4.2 m.c. and tune in this signal.
- Adjust the 4.2 m.c. topside padder for maximum output, while rocking the radio tuning.

### Alignment of band 2

- Connect antenna screw through a 400 ohm resistor to the signal generator.
- Leave both signal generator and radio dial at 3.6 m.c.
- Now adjust the underside trimmer screw OSC-2 to find signal and maximize output.
- Next adjust the underside trimmer screws ANT-2 and DET-2 to maximize output.
- Change the signal generator to 1.8 m.c. and tune in this signal.
- Adjust the 1.8 m.c. topside padder for maximum output, while rocking the radio tuning.

### Alignment of band 1

- Connect antenna screw through a 200 mmf condenser to the signal generator.
- Leave both signal generator and radio dial at 1.4 m.c.
- Now adjust the underside trimmer screw OSC-1 to find signal and maximize output.
- Next adjust the underside trimmer screws ANT-1 and DET-1 to maximize output.
- Change the signal generator to .6 m.c. and tune in this signal.
- Adjust the .6 m.c. topside padder for maximum output, while rocking the radio tuning.

The alignment procedure is now complete.

# SX-9 Super SKYRIDER by the hallicrafters

## SCHEMATIC DIAGRAM

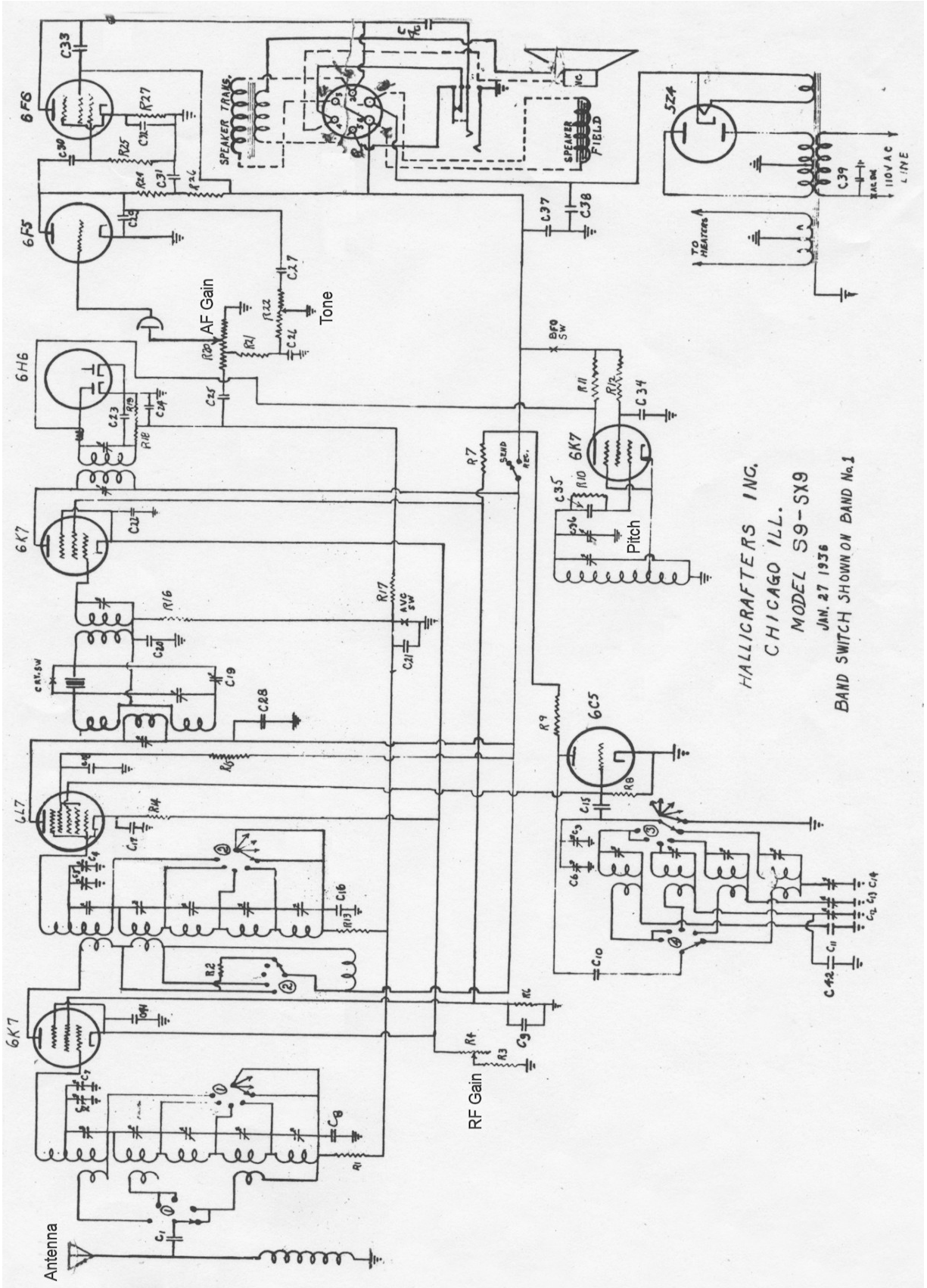

HALLICRAFTERS INC.  
 CHICAGO ILL.  
 MODEL S9-SX9  
 JAN. 27 1936  
 BAND SWITCH SHOWN ON BAND No. 1

# SX-9 Super SKYRIDER by the hallicrafters

## CHASSIS DIAGRAM

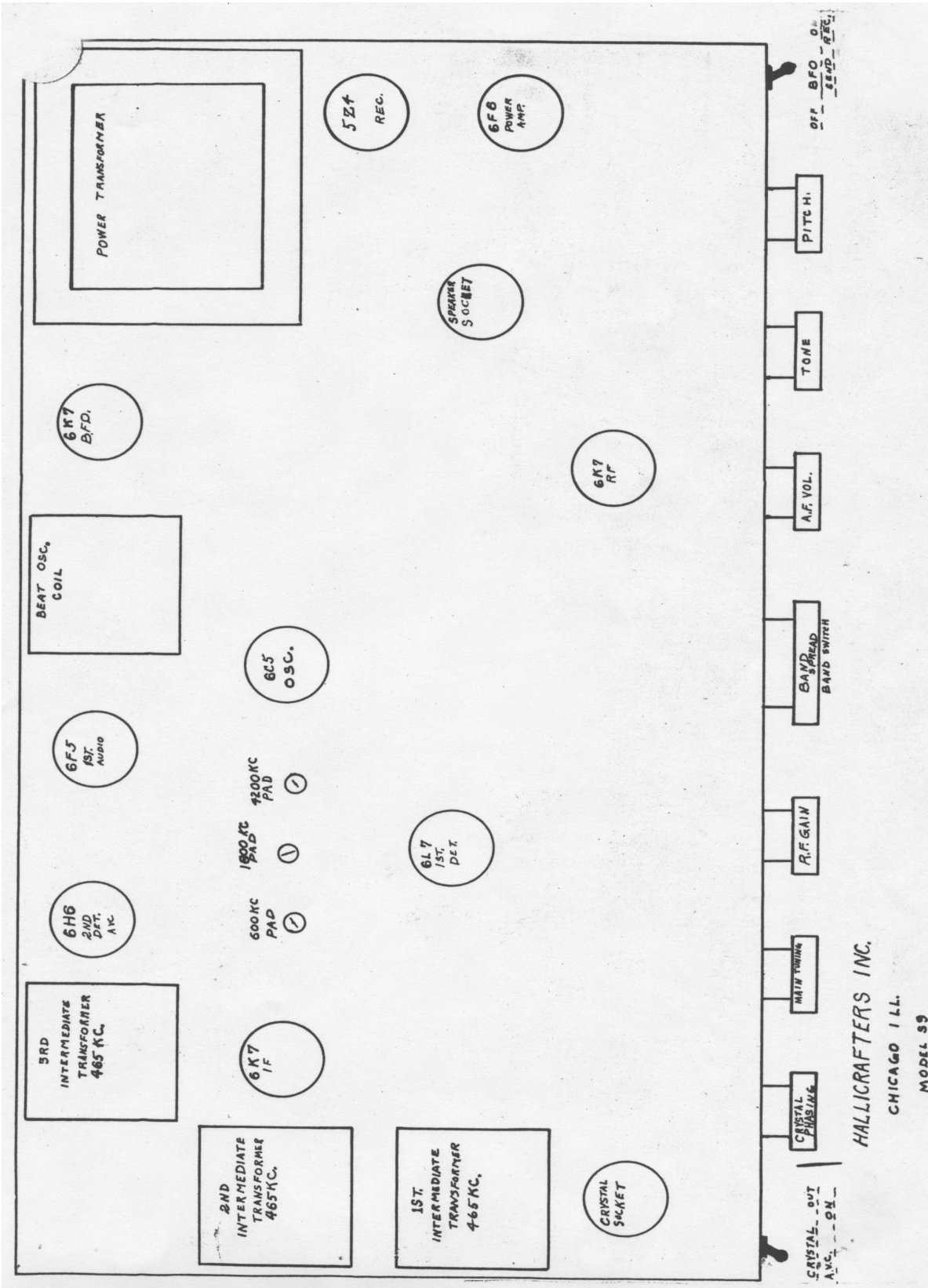



# SX-9 Super SKYRIDER by the hallicrafters

## COMPONENT LIST

No.	Value Ohms	Watts Rating	Tol.	Part No.	No.	Value Cap.	Volts Rating	Tol.	Type	Part No.
R1	100,000	1/3	20%	2093	C1	.00025	600V	20%	Mica	4007
R2	2,500	1/3	20%	2045	C2	.000028			Band Spread Con.	4802
R3	75	1/3	10%	2205	C3	.000028			"	"
R4	10,000	Receiving Gain		2500	C4	.000028			Main Tuning	4801
R5					C5	.000452			"	"
R6	25,000	1	20%	2073	C6	.000452			"	"
R7	25,000	1	20%	2073	C7	.000452			"	"
R8	50,000	1/3	20%	2084	C8	.005	600V	5%	Mica	4317
R9	25,000	1	20%	2073	C9	.1	400V	20%	Paper	4107
R10	100,000	1/3	20%	2093	C10	.002	600V	20%	Mica	4013
R11	100,000	1/3	20%	2093	C11	.003	600V	5%	Mica	4313
R12	50,000	1/3	20%	2084	C12	.0017-Appr.			Padders	
R13	100,000	1/3	20%	2093	C13	.001			"	One Strip-4400
R14	200	1/3	10%	2214	C14	.0004			"	"
R15	30,000	1	20%	2275	C15	.00005	600V	20%	Mica	4001
R16	100,000	1/3	20%	2093	C16	.005	600V	5%	Mica	4317
R17	1 Meg	1/3	20%	2108	C17	.05	200V	20%	Paper	4104
R18	20,000	1/3	20%	2072	C18	.25	400V	20%	Paper	4109
R19	500,000	1/3	20%	2102	C19	.000025			Crystal Phas.	4804
R20	1/2 Meg	AF Volume Control		2502	C20	.02	200V	20%	Paper	4102
R21	50,000	1/3	20%	2084	C21	.05	200V	20%	Paper	4104
R22	1 Meg	Tone Control		2503	C22	.1	200V	20%	Paper	4106
R23					C23	.00025	600V	20%	Mica	4007
R24	250,000	1/3	20%	2099	C24	.00025	600V	20%	Mica	4007
R25	250,000	1/3	20%	2099	C25	.05	200V	20%	Paper	4104
R26	100,000	1/3	20%	2093	C26	.002	600V	20%	Mica	4013
R27	500	1/3	10%	2419	C27	.004	600V	20%	Mica	4107
					C28	.25	400V	20%	Paper	4109
					C29	.0005	600V	20%	Mica	4009
					C30	.06	400V	20%	Paper	4105
					C31	.1	400V	20%	Paper	4107
					C32	5 mfd	25V	20%	Elec.	4200
					C33	.004	1000V	20%	Mica	4500
					C34	.06	400V	20%	Paper	4105
					C35	.00025	600V	20%	Mica	4108
					C36	.000025			Var. Cond.	4804
					C37	8 mfd	450V		Elec.	4210
					C38	8 mfd	450V		Elec.	4210
					C39	.05	400V	20%	Paper	4105
					C40	.005	1000V	20%	Mica	4501
					C41	.05	200V	20%	Paper	4104
					C42	.0005	600V	5%	Mica	4308

Jan. 27, 1936.