

**OPERATING
AND SERVICE
INSTRUCTIONS
FOR ...**

T.O. Keyer[®]
MODEL HA - 1

the hallicrafters co.



A Subsidiary of Northrop Corporation

SECTION I

GENERAL

1-1. DESCRIPTION

The Hallicrafters Model HA-1 T.O.Keyer ® employs digital circuitry, similar to that found in modern digital computers, to form perfect code characters at any speed. Experienced operators appreciate its stability and precision of operation, and novice operators discover a new command of CW that leads to proficiency and unsuspected enjoyment. The keyer operates much in the same way as a tape transmitter; the dash-dot and mark-space ratios remain constant over the speed range and the speed and mark-space adjustments are completely independent.

The key lever is a remote control unit that may be placed in any convenient operating position. This conserves the operating area, permits ready mechanical adjustments, and allows the operator his choice of key levers.

Additional features of the keyer include a pleasant sidetone signal with volume control for practice, instruction or monitoring ... an exceptionally wide speed range ... a silent mercury-wetted relay of virtually unlimited life ... complete immunity to line-voltage fluctuations and RF pickup ... rear connections for break-in operation and auxiliary control, and for external sidetone and key lever connections ... and a transformer power supply, with silicon rectifiers and complete voltage regulation for top reliability.

1-2. STANDARDS FOR THE INTERNATIONAL MORSE CODE

The International Morse code replaced the older Morse code for radio communications when the tape perforator and keying head, along with the high-speed ink-slip recorder, were developed for commercial service. This early automation of our CW is still widely employed, handling traffic comfortably at 300 WPM. The perforator and keying head provide the "perfect fist" and the standards for CW which make it easy to send and receive with the proper scientific economy.

The relative duration of the dot and the space is called the mark-space ratio, usually adjusted for 1-to-1. A dash is formed by bridging the space between two dots. The spaces between dots and dashes in a letter are uniform. A standard word is equivalent to 24 dot and spaces. 10 WPM (words per minute) is therefore 240 dots per minute, or 4 dots per second.

SECTION II

SPECIFICATIONS

POWER SOURCE	105 to 125 volts, 60 cycles AC, 25 watts.
SPEED RANGE	Low: 10 to 30 WPM. High: 25 to 65 WPM.
KEYING MONITOR	Self-contained tone generator and PM speaker. Rear chassis mounted PHONES jack disconnects speaker when phones are inserted.
TRANSMITTER KEYING	Mercury-wetted contact relay switching normally open or normally closed to ground. (See paragraph 3-4-1-2).
KEY LEVER INPUT	Three-circuit jack mounted on front panel accepts 1/4 inch diameter plug (Switchcraft type 267 or equivalent) or rear control outlet connections. (See paragraph 3-3).
CONTROL OUTLET	Eight-pin octal socket mounted on rear panel accepts standard octal plug (supplied).
DIMENSIONS (OVERALL)	5-5/8 × 7 × 7-13/16 inches (HWD).
NET WEIGHT	7-1/2 pounds.
SHIPPING WEIGHT	10 pounds.

SECTION III

INSTALLATION

3-1. UNPACKING

After unpacking the Model HA-1 keying unit, examine it closely for any possible damage which may have occurred during transit. Should any sign of damage be apparent, file a claim immediately with the carrier stating the extent of the damage. Carefully check all shipping labels and tags for any special instructions before removing or destroying them. Remove all protective shipping material around tubes and components.

3-2. LOCATION

The keyer should be placed in a location which permits free circulation of air around the cabinet, particularly at the rear. Avoid excessively warm locations such as those near radiators and heating vents.

The mercury-wetted relay employed requires that the keyer be operated in a position no greater than 30° from a horizontal plane.

3-3. KEY LEVER

Various styles of commercially built key levers are available for use with electronic keyers. Any of these are suitable for use with the Model HA-1 keying unit. Connections to the key and panel jack are made as shown in figure 2. Key lever connections are also provided at the control socket on the rear of the unit (See paragraph 3-4-1-1).

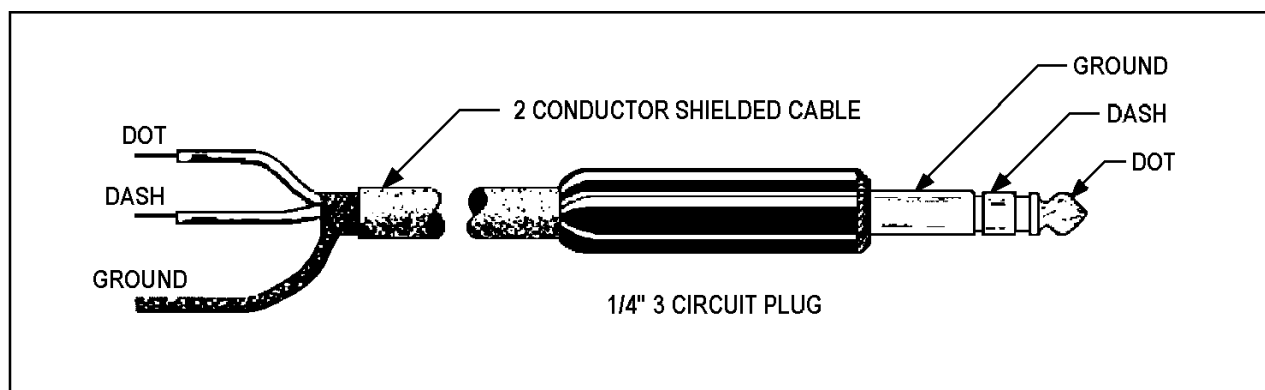

Figure 2. Key Lever Cord for Front Panel Key Connection.

It can be noted by referring to the schematic diagram, figure 9, that the key lever base is connected to chassis ground and the dot-dash contacts are operated at an extremely low negative potential. This makes the key assembly completely free from shock hazard.

3-4. REAR CHASSIS RECEPTACLES

Receptacles are provided on the rear of the keyer for the following purposes.

3-4-1. CONTROL OUTLET (See figure 3)

An eight-pin socket is provided to connect the Model HA-1 keying unit into the station control system. The mating connector for this socket is an Amphenol type CP-8 (one is supplied).

3-4-1-1. AUXILIARY KEY LEVER CONNECTIONS (Pin 1, 5 and 8)

At the user's option, the key lever may be connected to the control outlet instead of to the panel key jack. Pin 1 is chassis ground, pin 5 is switched to ground for dots, and pin 8 is switched to ground for dashes.

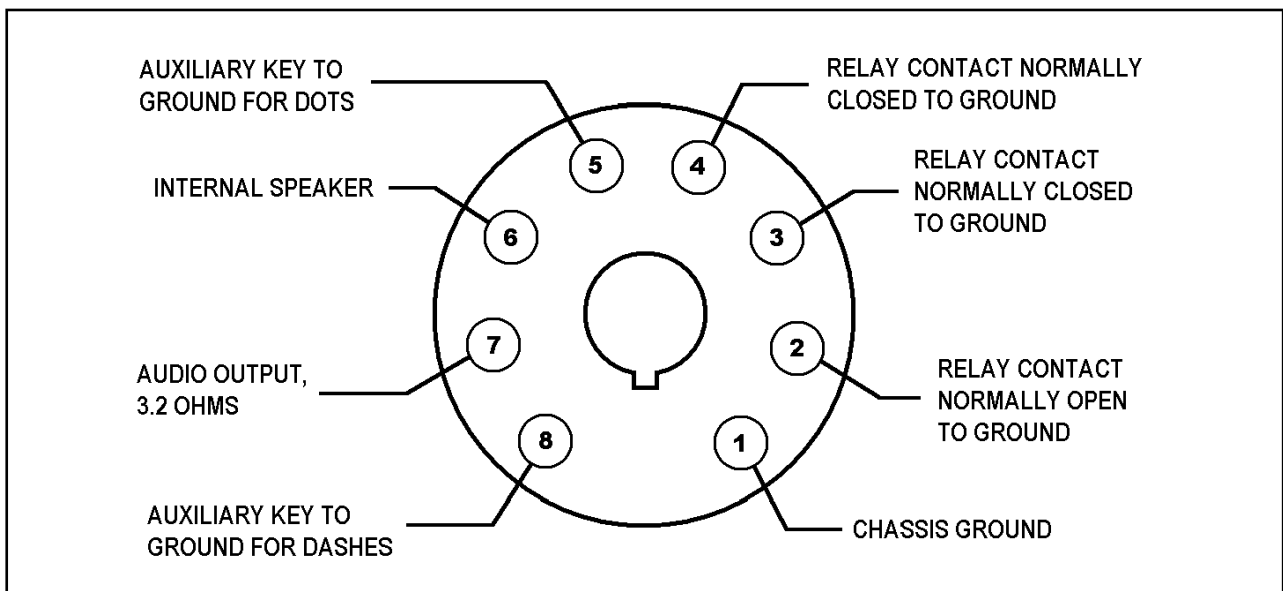

Figure 3. Control Outlet Connections.

3-4-1-2. KEYING CONTACTS (Pin 2, 3 and 4)

Pin 2 (normally open to ground) is normally used for transmitter keying purposes.

Pin 3 and 4 (independent, normally closed to ground) are provided for auxiliary control of station facilities.

IMPORTANT

The mercury-wetted relay contact rating is 5 amperes maximum, or 500 volts maximum, the product not to exceed 250 voltamperes with contact protection. For example, the maximum allowable voltage with a 5-ampere load is 50 volts ($5 \text{ A} \times 50 \text{ V} = 250 \text{ VA}$); the maximum allowable current with a 500-volt supply is 0.5 ampere ($500 \text{ V} \times 0.5 \text{ A} = 250 \text{ VA}$). Refer to paragraph 3-5 for method of determining required contact protection network.

3-4-1-3. Speaker (Pin 6) AND AUDIO OUTPUT (Pin 7)

A standard circuit transfer type PHONES jack (J1) on the rear apron automatically disconnects the internal speaker when the phone plug is inserted. Output impedance is 3.2 ohms, although it is suitable for use with any low or medium impedance headsets.

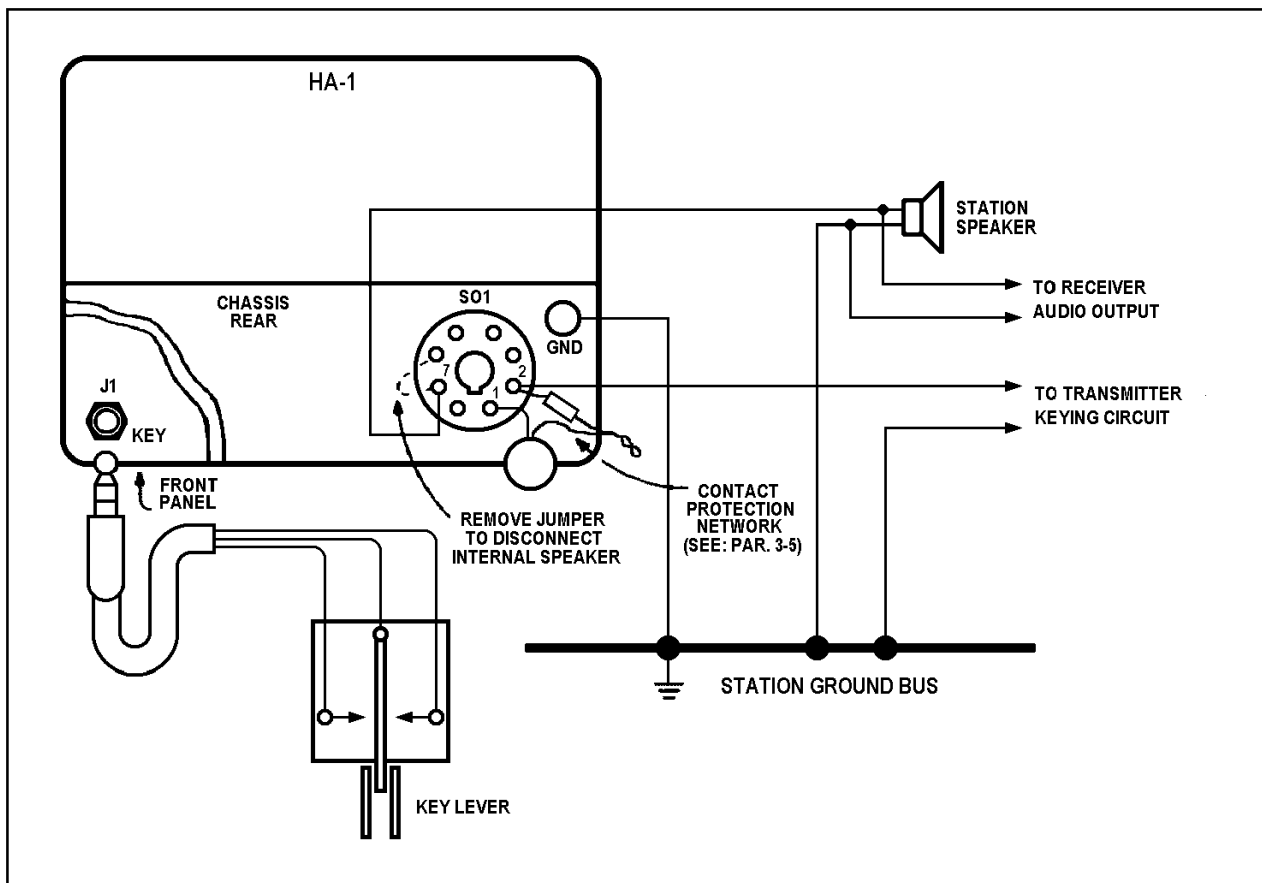

Figure 4. Typical Station Installation.

3-4-3. GROUNDING POST

The ground post, provided at the rear of the keyer, should be utilized to establish a ground for this unit.

IMPORTANT

It is recommended that the unit permanently connected to the station grounding system so as to prevent the possibility of a shock hazard developing as a result of component failure.

3-5. RELAY CONTACT PROTECTION NETWORK

Except for very light loads (under 2 mA and 50 V), the relay must be provided with a contact protection network consisting of a capacitor and resistor in series. This network is shown in the lower right-hand corner of the chassis in figure 4. The network prevents possible arcing which would eventually destroy the contacts. The voltage and current requirements of the circuit to be keyed should be determined, and the relay contacts provided with an appropriate protection network prior to the connection into the circuit.

The chart (figure 5) affords a convenient means of determining the necessary contact protection.

Hallicrafters Model HT-30, HT-32, HT-32A, HT-32B, HT-37, HT-44, SR-150 and SR-160 Transmitters require no protection network when used with this keyer.

For the most effective protection, the network, as determined from the chart, should be installed as close to the relay contacts as is possible. It is desirable to install the network internally, directly at the relay socket; however, adequate protection will be provided by installing the network at the network at the control outlet.

To determine the proper protection network required for loads exceeding 2 mA or 50 volts, proceed as follows:

- (1) Measure load current of circuit to be keyed with a suitable ammeter.
- (2) Measure open circuit load voltage at the keying points.
- (3) To find C, read directly up from the value of load current on the horizontal scale to its intersection with the sloping capacity line; the value of C is determined from the right hand scale.

To find R, read directly up from the load current value to its intersection with the appropriate load voltage line; the value of R is read from the left-hand scale.

Example I: A circuit maintaining a load current of 2.0 amperes and an open circuit load voltage of 100 volts would require a C value of 0.4 μF and an R value of approximately 3.6 ohms. (See dotted lines on chart).

Example II: Measured current and voltage is 50 mA and 150 V respectively.

Solution: The proper protecting network would be a 0.001 μF capacitor (Limiting capacity) in series with a 750 ohm resistor.

In current and voltage applications beyond the scope of the chart, the minimum limiting capacitance value of 0.001 μF and a maximum resistance value of 10,000 ohms should be used in the protection network.

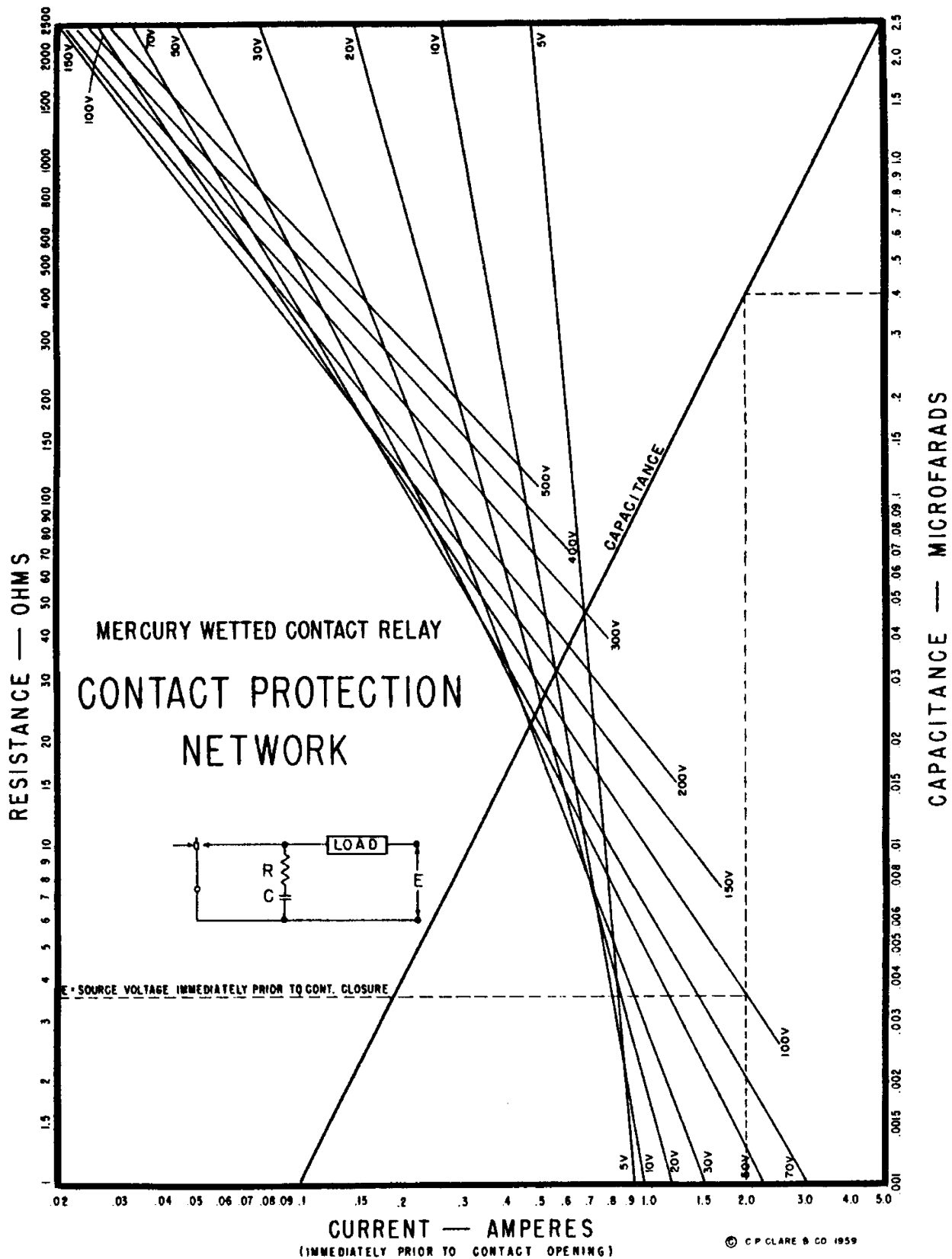

Figure 5. Relay Contact Protection Chart.

SECTION IV

FUNCTIONS OF OPERATING CONTROLS

4-1. FUNCTION SWITCH

The FUNCTION control is a four-position rotary switch: (1) turns the unit ON and OFF, (2) selects low or high speed operation, and (3) has a center HOLD position for transmitter tuning purposes (key down).

4-2. SPEED CONTROL

The SPEED control provides a means of adjusting the keying speed between 10 and 30 WPM when the FUNCTION switch is in the LOW position or between 25 and 65 WPM in the HIGH position.

4-3. SIDETONE CONTROL

The SIDETONE control (knurled shaft), accessible at the rear of the unit, adjusts the amplitude of the keyed monitor tone.

4-4. BALANCE CONTROL

The BALANCE control (screwdriver slot shaft), mounted at the rear of the unit, differentially adjusts the gain of tube V3 to compensate for tube section differences and aging. The adjustment should remain fixed for long periods of time and need only be readjusted when V3 is replaced or when major service has been performed.

To adjust the BALANCE control proceed as follows

- (1) Turn the control to its maximum counterclockwise position. The unit will key a continuous dash. Advance the control in the clockwise direction, and note the point at which the dash stops.
- (2) Turn the control to its maximum clockwise position and close the key to dash. The unit will key a continuous series of dots as long as the key is held closed to dash. Adjust the control counterclockwise to the point where self-completing dashes are formed. Note this setting.
- (3) Set the control midway between the points noted in step 1 and 2 above. The BALANCE control is now properly set and should require no further attention.

4-5. WEIGHT CONTROL

The WEIGHT control (knurled shaft), located on the rear panel, and referred to as the mark-space ratio adjustment, sets the time relationship of a dot (or mark) to its following space. For normal CW work this is usually set for a ratio of 1 to 1. Other ratios can be obtained to accommodate various transmitter keying characteristics or to suit personal preference (see figure 6).

To adjust the WEIGHT control, proceed as follows:

- (1) Turn the control to its maximum counterclockwise position; the unit will key a long mark with a short space.
- (2) Turn the control to its maximum clockwise position; the unit will key a short mark with a long space.

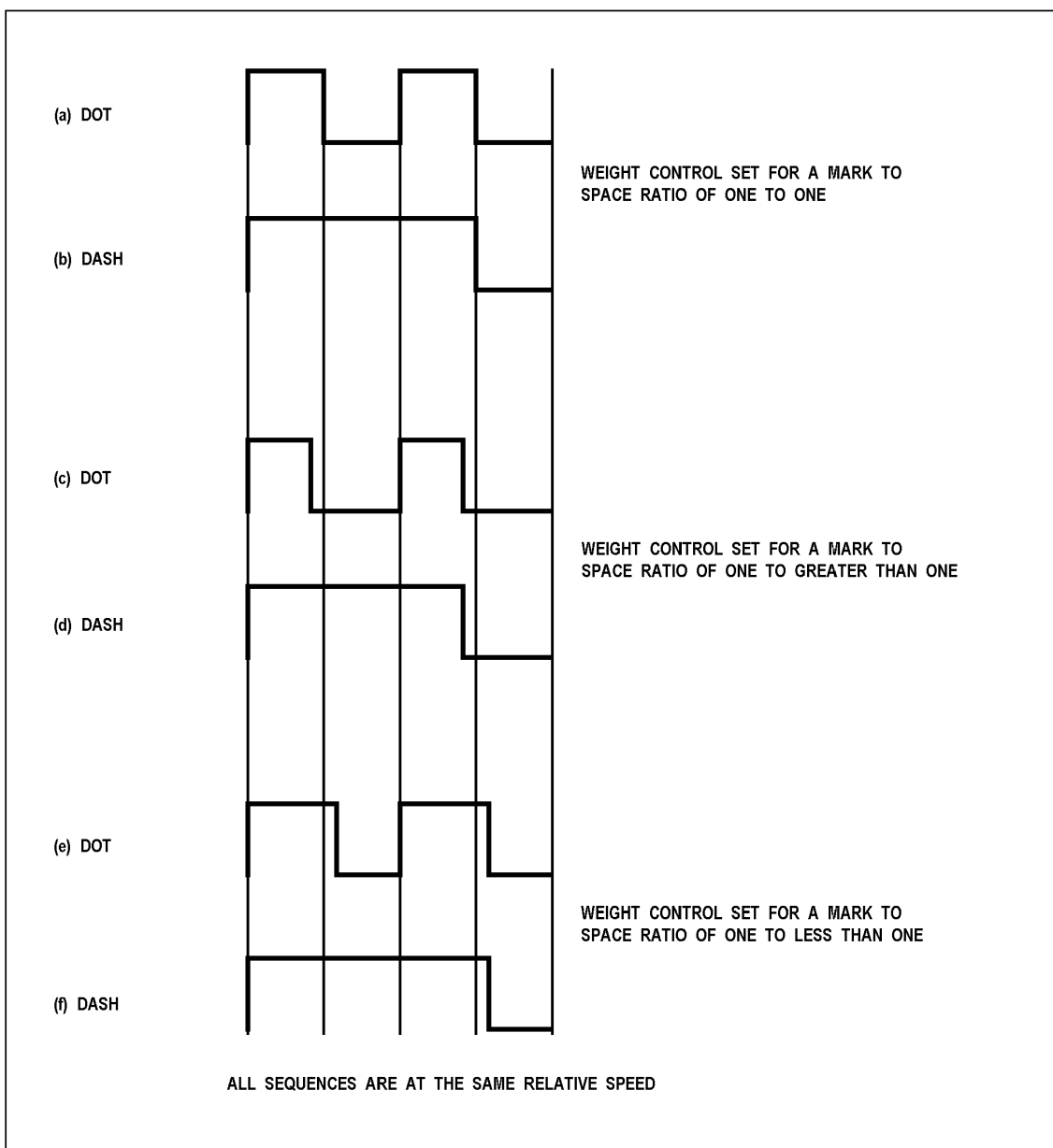

Figure 6. Dot-Dash-Space Relationship With Various Weight Control Settings.

The effect of the adjustment on keying characteristics is especially evident when listening to the keyed monitor signal with the unit running at its highest speed.

To set the WEIGHT adjustment for a 1 to 1 ratio at the relay terminals, proceed as follows:

- (1) Disconnect the keying leads from the transmitter and reconnect the leads to an ohmmeter. Set the ohmmeter to its lowest range.
- (2) key a continuous series of dots at a fairly high speed (approximately 45 WPM).
- (3) Adjust the WEIGHT control for a half-scale ohmmeter deflection.

Connecting an oscilloscope to the output of the transmitter so that the keyed output may be seen is a more accurate means of setting the desired ratio. This permits adjustment of the overall keying characteristic of the station although the method mentioned earlier, will generally suffice for most systems.

SECTION V

OPERATION

5-1. GENERAL

Rapid effortless operation of the keyer requires a certain "knack" that comes only with practice. Habits acquired by the use of conventional keys will have to be overcome before the full capabilities of the keyer can be realized.

Care should be exercised in the selection of a key lever for use with the Model HA-1 keying unit; one incorporating good mechanical construction, particularly at the pivot and contact points, is a desirable and will provide long reliable service.

Manufacturer's recommendations as to the keyer lever's adjustment should be closely followed for optimum performance. It is desirable to adjust the dot-dash contacts for the shortest possible excursion that will result in reliable make-break action. Key lever contacts should be periodically inspected to prevent the build-up of dirt and oxidation which can cause erratic keying.

5-2. OPERATING CHARACTERISTICS

The neon indicator on the front panel serves two functions: (1) it indicates that the power is on and the unit ready for use, and (2) it serves as a visual keying monitor. It will be noted that the indicator flashes once for each dot

formed and twice for each dash. In a perfectly formed character the rhythm of the flashes will be uninterrupted.

SECTION VI

THEORY OF OPERATION

6-1. GENERAL

The keyer forms dots and dashes by the use of digital circuitry and logical sequencing. Basic speed and mark-space ratios are established by a keyed multivibrator that operates continuously as dots and dashes are keyed to form a letter. Dashes are formed by adding the output of this time base (dot) generator with the output from a scale-of-two circuit. So formed, the dashes are always at the correct speed and mark-space ratios, as illustrated by figure 6.

6-2. CIRCUIT DESCRIPTION AND OPERATION ¹

Tube V1 is an astable (free-running) multivibrator which is keyed by series triode tube V2A. Positive feedback from V1A plate through resistor R16 holds V2A conducting after a momentary contact of the key lever to produce self completing dots. The dots are uniform whether momentarily initiated or fully keyed, as in a series. Speed is controlled by positive grid bias adjustment potentiometer R9. Speed range is determined by the selection of grid return resistors R1 and R6, or R2 and R7. Mark-space ratio is adjusted by differential grid resistor R8, with no effect upon speed.

Tube V3 is a triggered bistable multivibrator, or a scale-of-two circuit. When keyed by series triode tube V2B, it may be triggered by a negative pulse formed at the start of a dot from the plate of V1B. When so triggered, the plate of V3B will flip and remain positive until another negative pulse is received. Operating in this manner, it forms half-speed dots which are added to the output of V1 and drive the relay tube V4A to form perfect dashes.

¹ Patent Application Pending

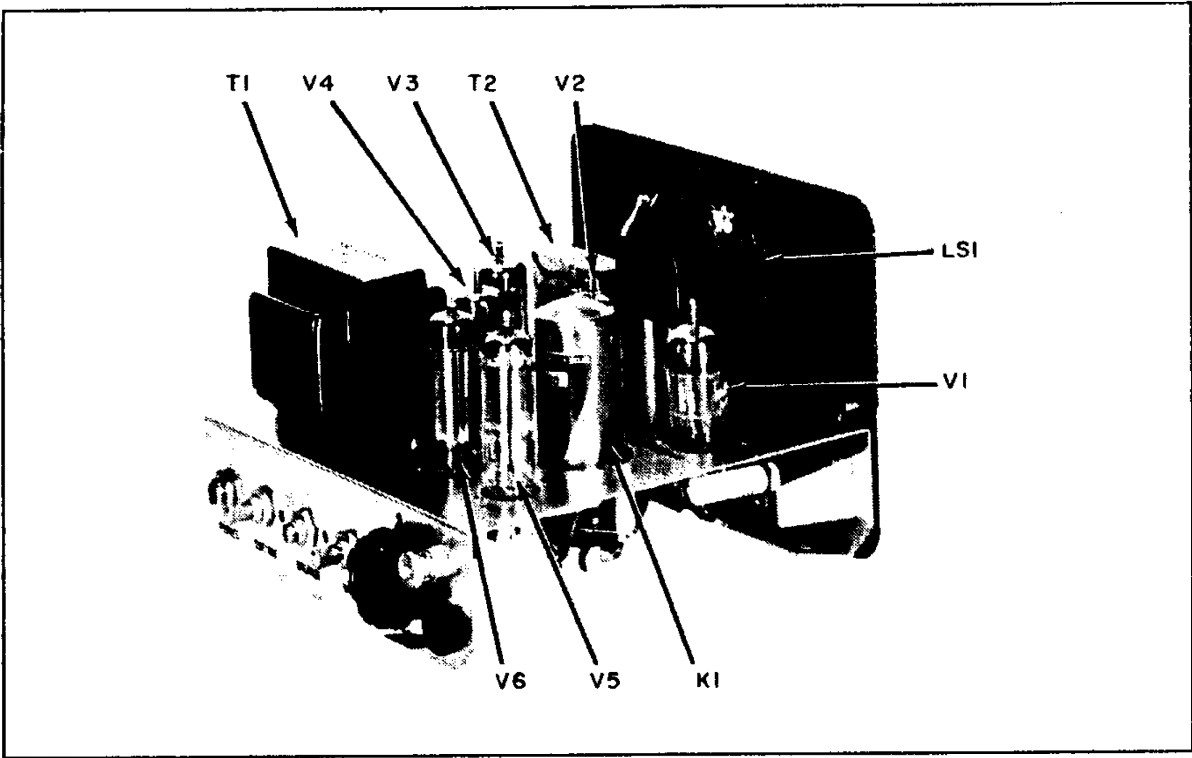

Figure 7. Model HA-1 Rear Oblique View.

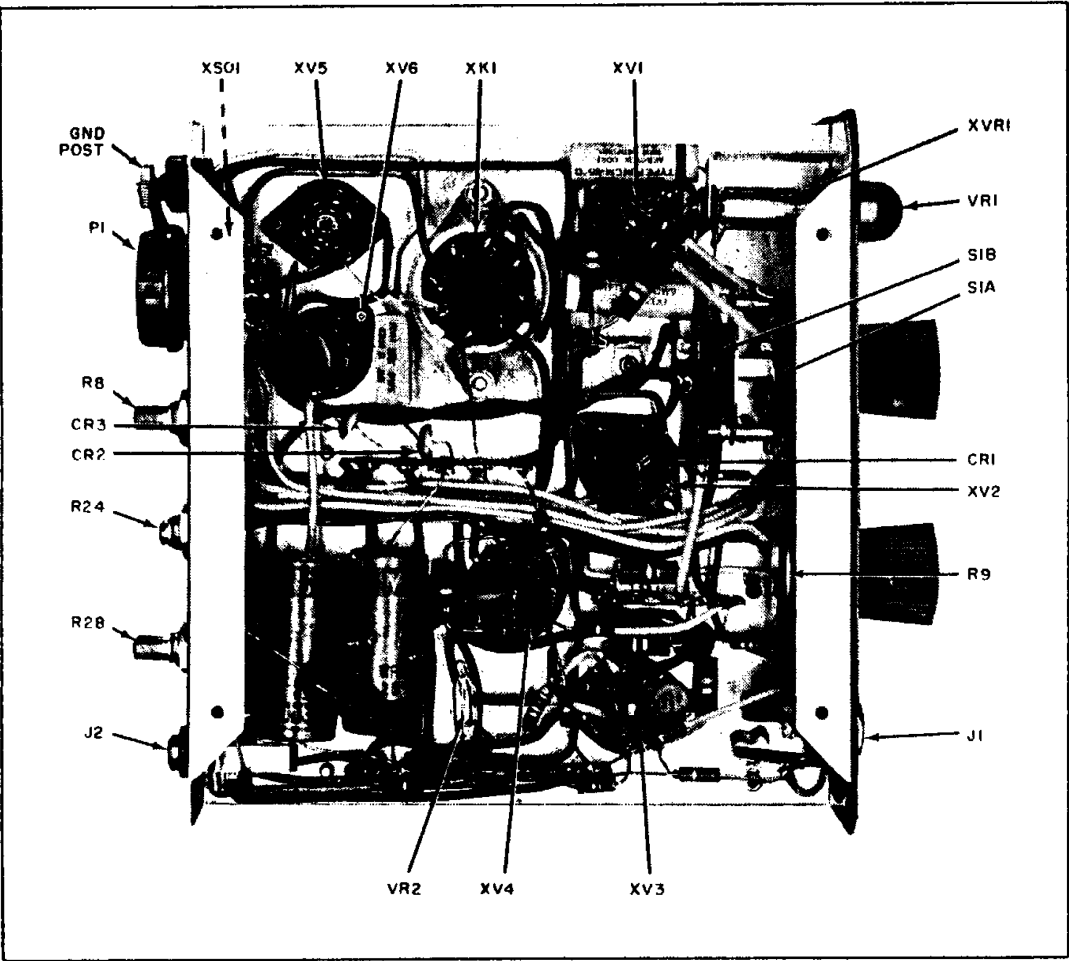

Figure 8. Model HA-1 Bottom Chassis View.

The sidetone signal is produced by a neon-type relaxation audio oscillator, amplified by V4B, and keyed by the relay. Frequency of the tone is determined by resistor R27 and capacitor C8. The sidetone level is controlled by potentiometer R28.

The power supply incorporates an electrostatically shielded transformer to minimize possible RF pickup and to provide complete isolation from the power line. Silicon rectifiers are used, and tubes V5 and V6 provide complete voltage regulation.

The self-completing dot is formed in the following manner:

- (1) The key lever contact closes momentarily.
- (2) With grid bias removed, tube V2A conducts.
- (3) Multivibrator V1 operates; V1A plate flips positive and trough R16 keeps V2A conducting to form a self-completing dot.
- (4) The output from the plate of V1A is applied through R15 to the grid of triode V4A which conducts and energizes relay K1.

The self-completing dash is formed as follows:

- (5) The key lever dash contact closes momentarily.
- (6) Tube V2B conducts to "arm" V3 for triggering.
- (7) At the same time, diode CR1 conducts to start a self-completing dot, as described in step 1 trough 4 above.
- (8) The leading edge of the negative-going dot from V1B plate through differentiator C3 and R12 forms a negative pulse to trigger V3.
- (9) The plate of V3B flips positive, keying V1 through CR1, until the leading edge of the second dot provides another negative pulse to flip it negative.
- (10) The second dot, already initiated, goes through completion to end the dash cycle.
- (11) The plate of V1A through R15, and the plate of V3B trough R14, drive the grid of V4A positive; V4A conducts and relay K1 energizes for a self-completing dash.

SECTION VII

SERVICE DATA

7-1. CHASSIS REMOVAL

The chassis and front panel assembly can be easily withdraw from the cabinet after the four screws on the bottom of the cabinet have been removed.

7-2. TUBE AND NEON LAMP REPLACEMENT

Complete access to all tubes can be obtained b removing the chassis from the cabinet (see paragraph 7-1). The neon lamp is accessible from the front of the cabinet.

7-3. TROUBLESHOOTING

Throughout the design of the Model HA-1 keying unit, full consideration was given to keep maintenance problems at an absolute minimum. However, if a malfunction does occur, the voltage chart and schematic diagram will aid in isolating and correcting the malfunction. For the physical location of component parts, refer to figures 7 and 8.

NOTE

The mercury-wetted relay will operate if inclined 30° or more from the horizontal plane.

7-4. Model HA-1 TUBE SOCKET VOLTAGES

Tube	1	2	3	4	5	6	7	8	9
V1	115	120	120	GND	H	21	0	GND	N.C.
V2	1	-17	GND	GND	H	120	-10	GND	N.C.
V3	12	0	GND	GND	H	105	-12	1	N.C.
V4	150	-15	GND	GND	H	150	0	4	N.C.
V5	150	N.C.	N.C.	N.C.	N.C.	N.C.	GND	--	--
V6	GND	N.C.	N.C.	N.C,	N.C.	N.C.	-108	--	--

NOTES:

1. Measurements were made with a vacuum tube voltmeter connected between indicated tube socket terminal and chassis.
2. Measurements were made with the FUNCTION switch in the LOW position; SPEED control maximum clockwise; BALANCE and WEIGHT

controls at the center of rotation; and SIDETONE maximum counterclockwise.

3. Indicated voltages may vary $\pm 20\%$.

7-5. SERVICE AND OPERATING QUESTIONS

For further information regarding operation or servicing of this equipment contact the dealer from whom the unit was purchased. The Hallicrafters Company maintains an extensive system of Authorized Service Centers where any required service will be performed promptly and efficiently at no charge if this equipment is delivered to the service center within 90 days from the date of purchase by the original buyer and the defect falls within the terms of the warranty. It is necessary to present the Bill-of-Sale in order to establish warranty status. After expiration of the warranty, repairs will be made for a nominal charge. All Hallicrafters Authorized Service Centers display the sign shown at right. For location of the one nearest you, consult your dealer or your local telephone directory.



Make no service shipments to the factory unless instructed to do so by letter, as The Hallicrafters Company will not accept responsibility for unauthorized shipments.

The Hallicrafters Company reserves the privilege of making revisions in current production of equipment and assumes no obligation to incorporate such revisions in earlier models.

REPAIR PARTS LIST

Schematic Symbol	Description	Hallcrafters Part Number	Schematic Symbol	Description	Hallcrafters Part Number
CAPACITORS					
C1,2	.02 μ F, 10%, 200V, Molded Tubular	494-011203	V1,2,3	Tube, Type 5963 (or 12AU7A)	090-901240
C3,9	.001 μ F, 20%, 400V, Molded Tubular	494-024102	V4	Tube, Type 12AU7A	090-901291
C4,5,8	.001 μ F, 20%, 500V, Ceramic Disc	047-100503	V6	Tube, Type OA2	090-900001
C6,7,12,13	.02 μ F, +80%, -20%, 500V, Ceramic Disc	047-100242	V6	Tube, Type OB2	090-900005
C10,11	20 μ F, 250V, Electrolytic	045-000685	VR1	Lamp, Neon, Type NE51	039-100499
C14	.005 μ F, 20%, 500V, Ceramic Disc	047-100442	VR2	Lamp, Neon, Type NE2 (with leads)	039-100012
*RESISTORS					
R1,6,15,17,19,25	2.2 megohm	451-251225	CR1	Diode, Silicon, Type 1N1763A	019-004286
R2,7	5.6 megohm	451-251565	CR2,3	Diode, Silicon, Type 1N3195	019-002770
R3,5,11,13	100K ohm, 1 watt	451-351104	SWITCHES		
R4	100K ohm, 10%	451-252104	S1A	Rotary, Wafer, FUNCTION	080-003445
R8	1 megohm, WEIGHT control	025-001849	S1B	ON-OFF (Part of S1A)	-----
R9	100K ohm, SPEED control	025-003305	SOCKETS AND CONNECTORS		
R10	10K ohm	451-251103	XV1	Socket, 9-pin	006-000927
R12	22K ohm, 10%, 1 watt	451-352223	XV2,3,4	Socket, 9-pin Noval	006-000907
R14	1 megohm	451-251105	XV5,6	Socket, 7-pin Miniature	006-200457
R16,18	680K ohm	451-251684	KK1	Socket, Octal, Relay	006-100796
R20,21,22,23	470K ohm	451-251474	XVR1	Socket, Dial Light	086-000507
R24	500K ohm, BALANCE control	025-001851	SO1	Socket, 8-pin Octal	006-200296
R27	2.7 megohm, 10%	451-252275	P1	CONTROL OUTLET	035-100003-01
R28	2 megohm, SIDETONE control	025-001850	P2	CONTROL OUTLET	087-100078
R29	560 ohm, 10%, 1 watt	451-352561	J1	Plug and Line Cord, AC Input	036-000254
R30	2200 ohm, 10%, 5 watt, wire wound	024-001328-03	J2	Jack, KEY	036-100002
R31	47 ohm, 10%	451-252470	MISCELLANEOUS		
R32	10 ohm, 10%	451-252100	K1	Relay, Mercury Wetted	021-000528
*All Resistors are carbon type, 1/2 watt, 5%, unless otherwise indicated.					
TRANSFORMERS					
T1	Transformer, Power	052-000786	LS1	Shield, Lamp	069-001331
T2	Transformer, Audio	055-000523		Speaker	085-000207
				Trim Strip	007-001501
				Bushing, Line Cord Lock	076-100397
				Cabinet	066-002857
				Feet	016-201072
				Eyelet	005-300218
				Knob	015-001775
				Panel	068-001056
				Relay, Mercury Wetted	021-000528
				Retainer, Tube	076-202277
				Shield, Lamp	069-001331
				Speaker	085-000207
				Trim Strip	007-001501

